

# Mk5 Range

**Tough proven, reliable designs available with single or double acting capabilities**

Whale's most versatile high performance pump design.  
3 mounting orientations – 1 pump

Product code: see table

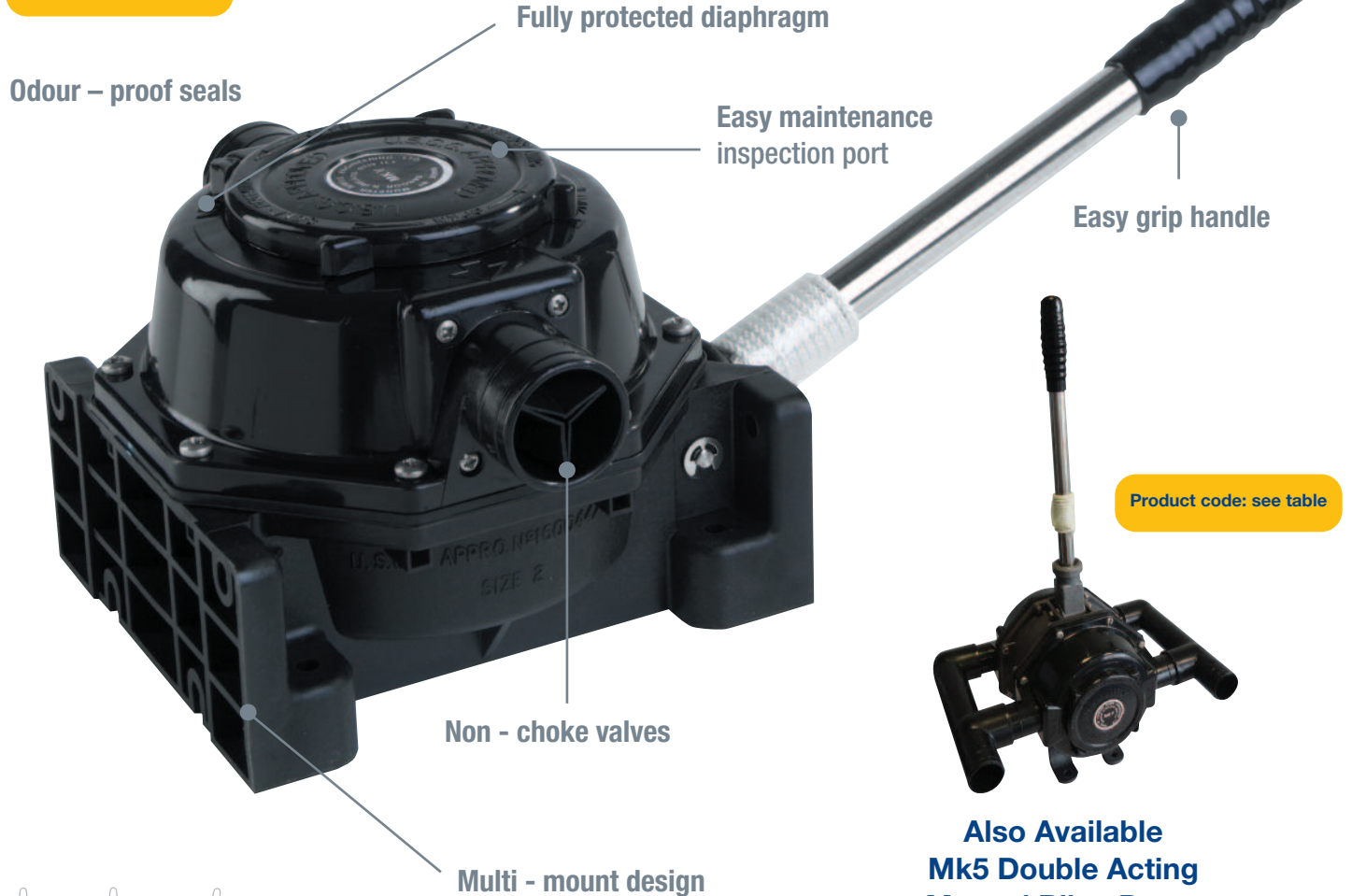

Product code: see table



## Also Available Mk5 Double Acting Manual Bilge Pump

High output - 104 ltrs (23 US gals) per minute  
Twin diaphragms - empty 2 bilge compartments at the same time or one twice as quickly - 2 manifolds supplied

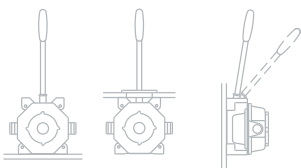

On-Deck Front view    Thru-Deck Front view    On-Bulkhead Side View  
3 mounting options in 1 pump

# Mk5 Universal

- Three mounting options. A design that has been tried tested and trusted by sailors for decades. This clever bilge pump design allows great versatility in installation so that you can fit the pump in the orientation to best suit your boat.
- Whale's most versatile high performance pump design
- 3 mounting orientations  
1 pump (on-deck, thru-deck, on-bulkhead)
- High Performance – flow rate  
66 ltrs (17.5 US gals) per min

# Mk5 Double Acting

- High performance
- Ease of maintenance  
inspection hatch - no tools required
- Will continue to pump even if one diaphragm fails

## 5 Year Warranty

**Tips** It is important to ensure that a vented anti-syphon loop is incorporated in the system

## Awards and Accreditations

- Suitable as a primary bilge pump on boats equal to or greater than 12m (40ft) in accordance with ISO15083

## Life Boats Approval

- Approved by Lloyds (MCA) and USCG (Mk5 Universal MCA - Size 2) (Mk5 Double Acting - Size 3)

## Product Information

### Model Specifications

Model	Mk5 Universal Pump (Multiple Mounting Options)	Mk 5 - Double Acting Pumps		
Product Code	BP0510	MH5550 On bulkhead	MH5560 Thru deck	MH5570 On deck
Weight	1.36 kg (3.0 lbs)	2.8 kg (6 lbs)		
Hose Connections	38 mm (1½") Hose Connections			
Materials	Pump Body: Glass-filled Polypropylene, Diaphragm Valves and Seals: Nitrile®, Operating Lever: Acetal, Glass-filled Nylon Spring and Fasteners: Stainless Steel			
Materials In Contact With Fluid	Glass-filled Polypropylene, Acetal, Nitrile®, Stainless Steel			
Service Kit	<b>Service Kits for Mk 5</b> AK8050 - Service Kit for Mk5 Contains: Diaphragms, Valves and Circlips AS0511 - Spare Handle AS0521 - rocker arm assembly AS0522 - Front cover / body assembly AS0531 - Under deck rocker arm assembly	<b>Service Kits for Mk 5 D Acting</b> AK8060 - Service Kit for Mk 5 D Acting - contains: Diaphragms, Valves and Circlips AS8551 - Rocker arm assembly AS8552 - Clamping plate and nut kit		
Accessories	AS3725 Gaiter Kit, DP9906 - Deck Plate Kit (includes cover)			
Maximum Suction Lift	4.5 m (15 ft)			
Maximum Discharge Head	4.5 m (15 ft)			

## COMPLETE YOUR SYSTEM

Whale high quality bilge accessories including non-return valves, elbows and Y pieces see page 48 - 51

### Performance Data

	Mk5 Universal Pump	Mk 5 - Double Acting Pumps
Suction Lift	1 m (3 ft)	
Discharge Head	0.5 m (1.5 ft)	
45 Strokes per Minute	42 ltrs (11 US gals)	64 ltrs (17 US gals)
70 Strokes per Minute	66 ltrs (17.5 US gals)	104 ltr (27.5 US gals)

