



Pump Accumulator Kit

UF2014 / UF2015 / UF2025 / UF8025

## INSTALLATION & USER INSTRUCTIONS

Thank you for purchasing this Whale® product.

For over 60 years Whale has led the way in the design and manufacturer of freshwater and waste systems including:- plumbing, faucets, showers and pumps for low voltage applications. The company and its products have built a reputation for quality, reliability and innovation backed up by excellent customer service.

For information on our full product range visit: [www.whalepumps.com](http://www.whalepumps.com)

### CONTENTS

1. Principles of Operation
2. Specification
3. Application
4. Warnings
5. Parts List
6. Instructions for Installation
7. Maintenance
8. Trouble Shooting
9. Winterising
10. Service Support Details
11. EU Declaration of Conformity
12. Patents and Trademarks
13. Warranty

### Read the following carefully before installation

#### To the Fitter:

Check that the product is suitable for the intended application. Follow these installation instructions and ensure all relevant personnel read the points listed below. Also ensure that these operating instructions are passed on to the end user. The manufacturer cannot be held responsible for claims arising from incorrect installation, unauthorised modification or misuse of the product.

#### To the User:

Read the following instructions carefully.

## 1. PRINCIPLES OF OPERATION

The function of a pump accumulator kit is to provide smooth flow from the system with reduced pump cycling.

## 2. SPECIFICATION

Product Code	UF2014	UF2015	UF2025	UF8025
Pressure Pump	Universal (UF1214)	Universal (UF1215)	Universal (UF1225)	Universal (UF1825)
Flow Rate	11.5ltrs/min (3.0 US Gals/min)			18ltrs/min (4.75 US Gals/min)
Voltage	12 V d.c.		24 V d.c.	24 V d.c.
Cut out Pressure	2 bar / 30 psi	3 bar / 45 psi		
Accumulator Tank Size	2ltrs / 0.53US Gals			8ltrs / 2.2US Gals
Weight (non operational)	5.4kg / 11.9lbs			5.9kg / 13.0lbs
Factory Pre-charge Pressure +/-0.14 bar +/- 2psi	1.5 bar / 22psi	2.2 bar / 32psi		
Inlet Size	Whale® Quick Connect 15mm Female Connections			
Outlet Size	¾" female			
Hose Connection (Inlet)	For ½" Flexible hose use WX1584 Stem Adaptor or WX1591 Stem Elbow			N/A
Materials in contact with liquid	Glass filled polypropylene, Santoprene, Nitrile, Stainless steel, Butyl			
Minimum Wire Size	2.5mm <sup>2</sup> (20SWG)			
Maximum Head	20m (66ft)	30m (98ft)		
Maximum Lift	3m (10ft)			

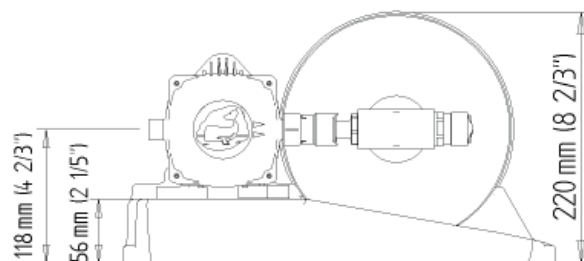
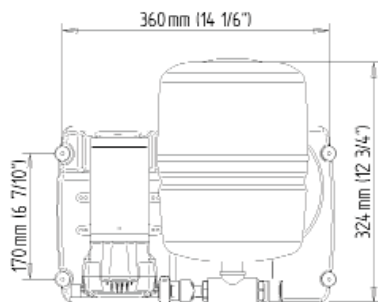

### 3. APPLICATION

The Whale® Accumulator kit is designed for installation in recreational marine vessels for saltwater or freshwater use, with 12 V d.c. or 24 V d.c. electrical supply only. If it is intended for use for any other purpose or with any other liquid, it is the user's responsibility to ensure that the pump is suitable for the intended use and, in particular, that the materials are fully compatible with the liquids to be used.

### 4. WARNINGS

1. This pump is designed for supplying water in a marine vessel. If it is intended for use for any other purpose it is the user's responsibility to ensure that the pump is suitable for the intended use.
2. **Not** suitable for pumping flammable liquids, diesel, chemicals etc. Only suitable for freshwater and saltwater.
3. A Whale® strainer **must be** fitted on the inlet side of the pump to prevent any dirt/debris entering the pump
4. With all applications, it is important that a system of safe working practice is applied to installation, use and maintenance. Ensure the electrical supply is turned off and water system is drained before installation. In order to securely fasten the unit, ensure that the mounting surface is a minimum thickness of 19mm (3/4") when fitted.
5. **NOTE: Do not** screw directly into the hull. **Must be** mounted on a bulkhead or additional board.
6. **CAUTION:** Pump **not** intended for continuous use
7. **WARNING:** Fire hazard. Wiring **must comply** with applicable electrical standards and include a properly sized fuse or circuit breaker. Improper wiring can cause a fire resulting in injury or death. Switch off the power while making connections. Suggested wiring information is given as guidance only. For full information, refer to the USCG, ABYC and ISO regulations for marine applications and wiring gauges, connectors and fuse protection.

### 5. INSTRUCTIONS FOR INSTALLATION

The following guidelines should be followed to achieve optimum pump performance.

#### MOUNTING LOCATION

1. Locate in a dry position, free of submersion and spray, with adequate ventilation, no more than 3 metres above the water tank.
2. The kit can be mounted horizontally or vertically (we recommend the pump head is below motor level).
3. We recommend the kit is secured using nuts and bolts or stainless steel screws. (Washers must be used.)

#### Typical Installation

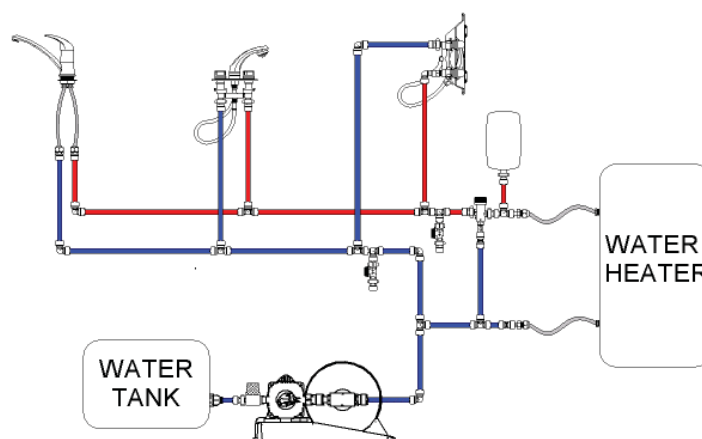

#### ELECTRICAL

1. Use specified fuse, as indicated on motor label, in the circuit.
2. Connect red wire to positive and black wire to negative - recommended wire size should be (2.5mm<sup>2</sup>).
3. Fit an adequate isolating switch on the positive side of the supply.
4. To prevent the pump running continuously, turn off at isolating switch when boat/caravan/R.V is left unattended or water supply has been allowed to empty.

## PLUMBING

1. Installation of an easy-clean filter/strainer is recommended. Always attach strainer to inlet side of pump.
2. Check pump flow direction (as indicated on pump body).
3. Never use pipe sealant or sealing tapes on the threads. These may enter the pump and cause failure.

If water is allowed to freeze in the system, serious damage to the pipework and pump may occur. To best avoid this damage, completely drain the water system.

## 6. MAINTENANCE

Periodic check of the complete water system by a professional installer is recommended at least once a year. During such a check, the precharge of the tank should be verified and adjusted if required

## 7. TROUBLE SHOOTING

Fault	Cause	Solution
Pump doesn't run.	No power to the pump. Fuse has blown.	Check supply. Attach leads/clean connections. Replace fuse.
Pump runs but no water appears.  Water leak.	Blockage in pipework No water getting to pump.  Pipework leaks at outlet side of pump.	Check pipework for kinks & filters etc. are clear. Check water supply level. Check strainer is clear. Check pipework/fittings for leaks & repair. Check pipework & fittings for leaks & repair. Check system bleed valve/s are closed.
Pump runs but will not switch off.	Water leaks at outlet side.  No water. Air getting into system.	Check pipework/fittings for leaks & repair. Check taps/shower for leaks & repair. Check water supply level. Check pipework/fittings (on supply side) for leaks & repair.
Pump cycles on/off periodically when all taps are closed. (Normal with partially opened tap)	Water leaks at outlet side.  Excessive dirt in the system	Check pipework/fittings for leaks & repair. Check taps/shower for leaks & repair. Ensure filter is fitted to inlet of pump. Run pump continuously for 5 minutes with all outlets and valves open.
Pump cycles on & off excessively when tap/s are open.	Excessive back pressure between pump and accumulator tank. Incorrect tank pre-charge pressure.	Check connections for blockage and repair.  Turn power off - release all pressure in system. Check pre-charge is at recommended level.
Noisy operation.	Pump drawing air.  Noise created by vibration.	Check pipework/fittings (on supply side) for leaks & repair. Check pump is secured to solid surface. Check pump body is clear of hard surfaces. Locate away from interfering surfaces. Check pipework is securely supported.

## 8. WINTERISATION

1. Drain the water tank either using the pump or a drain valve.
2. Open all the faucets (including drain valve) and allow pump to purge the water from the system, then turn the pump off.
3. Disconnect the pump kit and turn on to purge into an adequate basin. Only connect pump kit again when it is to be used.
4. Remember to leave all faucets including showers open to avoid any damage.

## 9. SERVICE SUPPORT DETAILS

For installation or service advice please contact Whale® Customer Support:

Tel: +44 (0)28 9127 0531  
Email: [info@whalepumps.com](mailto:info@whalepumps.com)  
[www.whalepumps.com](http://www.whalepumps.com)

## 10. EU DECLARATION OF CONFORMITY

We hereby declare, under our sole responsibility, that the enclosed equipment complies with the provisions of the following EC Directives.

Electromagnetic Compatibility Directive 2004/108/EC on the approximation of the laws of the Member States relating to electromagnetic compatibility.

CE mark affixed: March 2014

Basis on which conformity is declared - The above equipment complies with the protection requirements of the EMC Directive.

Standards applied

94/25/EC amending 2003/44/EC

ISO10133:2000

EN55014-1:2006

EN55014-2:1997+A2:2008

EN28846 :1993

ABYC-H23

Recreational Craft Directive

Extra-low voltage DC Installation

EMC Emissions

EMC Immunity

Ignition Protection

Installation of Potable Water



Richard Bovill  
Engineering Director

## 11. PATENTS AND TRADEMARKS

WHALE® and GUSHER® are registered trademarks of Munster Simms Engineering Limited, Bangor, Northern Ireland trading as Whale and Whale Seaward Inc.

## 12. WARRANTY

This Whale® product is covered by a 2 year warranty. Please see the enclosed document for details of our Statement of Limited Warranty.

©Copyright Whale 2015 - All rights reserved.

Whale's policy is one of continuous improvement and we reserve the right to change specifications without prior notice. Illustrations are for guidance purposes only. Please note that by contacting Whale® Support you will be indicating your consent to receiving product updates, recall information, help guides and appropriate marketing messages from us via post, email or telephone unless you indicated an objection to receiving such messages.

Periodic check of the complete water system by a professional installer is recommended at least once a year. During such a check, the precharge of the tank should be verified and adjusted if required.

