



Whale Twist™ Deck Shower

NEW



A Radical Innovation in Deck Showers

Putting control in your hands

Unique Integrated Handset

- Incorporates temperature and flow controls
- Easy to use-streamlined ergonomic design
- High quality UV resistant ASA materials

No Lids or Covers

- Deck Protect™ End Cap creates a splash-proof seal

Ease of Installation

- Compact unobtrusive housing
- Only one circular hole to cut and simple plumbing connection

Mounts in Convenient Locations

- Housing options offer a choice of horizontal or vertical mounting on a flat or curved surface

Colour options available



Blue / White Models



Pale Grey / White Models

Whale
Twist™
Putting control in your hands

Whale Twist™ Handset

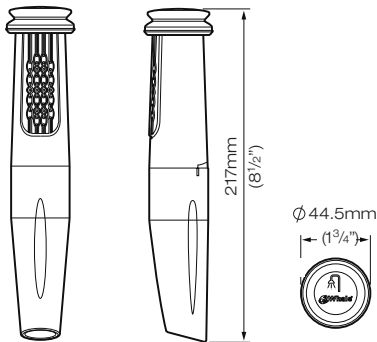

WHALE TWIST™ MODELS AVAILABLE

| Product Code | Description |
|--------------|---|
| DS0001B | Whale Twist™ Deck Shower Cold only handset (blue and white) with straight housing (chrome) 2.5 m (8.2 ft) hose |
| DS0002B | Whale Twist™ Deck Shower Cold only handset (blue and white) with angled housing (white) 2.5 m (8.2 ft) hose |
| DS0003B | Whale Twist™ Deck Shower Mixer handset (blue and white) with straight housing (chrome) 2.5 m (8.2 ft) hose |
| DS0004B | Whale Twist™ Deck Shower Mixer handset (blue and white) with angled housing (white) 2.5 m (8.2 ft) hose |
| DS0011B | Whale Twist™ Deck Shower Cold only handset (pale grey and white) with straight housing (chrome) 2.5 m (8.2 ft) hose |
| DS0012B | Whale Twist™ Deck Shower Cold only handset (pale grey and white) with angled housing (white) 2.5 m (8.2 ft) hose |
| DS0013B | Whale Twist™ Deck Shower Mixer handset (pale grey and white) with straight housing (chrome) 2.5 m (8.2 ft) hose |
| DS0014B | Whale Twist™ Deck Shower Mixer handset (pale grey and white) with angled housing (white) 2.5 m (8.2 ft) hose |
| DS0411B | Whale Twist™ Deck Shower Cold only handset (pale grey and white) with straight housing (chrome) 4 m (13.1 ft) hose |
| DS0412B | Whale Twist™ Deck Shower Cold only handset (pale grey and white) with angled housing (white) 4 m (13.1 ft) hose |
| DS0413B | Whale Twist™ Deck Shower Mixer handset (pale grey and white) with straight housing (chrome) 4 m (13.1 ft) hose |
| DS0414B | Whale Twist™ Deck Shower Mixer handset (pale grey and white) with angled housing (white) 4 m (13.1 ft) hose |

Note: These Whale Twist™ Deck Shower Models are bulk packed in outer carton quantities of 5

Ease of installation

The new Whale Twist™ Deck Shower is quick and easy to install. It is available with either a chrome straight housing, or a white angled housing, both of which require only a single circular hole to be drilled.

Plumbing

All Whale Twist™ Deck Shower models are easy to plumb. Mixer models include a shut off valve as standard.

Aesthetics

The Whale Twist™ Deck Shower is also available in a choice of either blue and white or pale grey and white colour combinations, with a chromed end cap and white 2.5 m (8.2 ft) or 4 m (13.1 ft) length hose both as standard.

Whale's policy is one of continuous improvement and we reserve the right to change specifications without prior notice. WHALE™, WHALE TWIST™ and DECK PROTECT™ are trade marks of Munster Simms Engineering Limited (also trading as Whale Water Systems).

| MODEL | WHALE TWIST™ DECK SHOWER |
|------------------|---|
| Weight | 130 g (0.3 lbs) |
| Hose Length | 2.5 m (8.2 ft) / 4 m (13.1 ft) |
| Hose Connections | 1/2" threaded connections |
| Materials | <p>Body - ASA</p> <p>Internal parts - TPE, Nitrile, POM</p> <p>Hose - Reinforced Polyurethane,</p> <p>Hose connections - POM and Nitrile,</p> <p>Straight Housing - Chromed ABS, glass-filled Polypropylene and Nitrile,</p> <p>Angled Housing - ASA</p> <p>End Cap - Chromed ABS,</p> <p>Screws and Hose Clips - Stainless Steel</p> |

Angled Housing Option

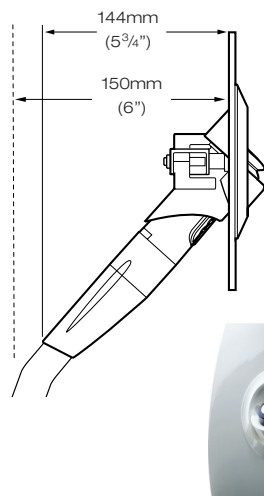
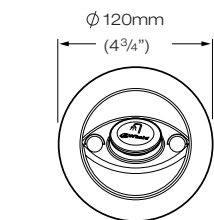

Straight Housing Option

